

RS Fanfold HS

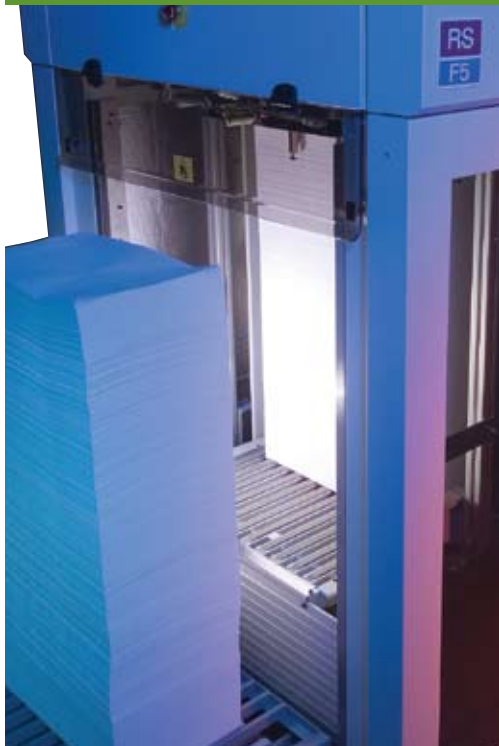

The RS Fanfold HS solution includes the RS Unwind and RSF5 Folder.

- High capacity fanfold handling
- Automatic thread-up
- Pinless or pinfed forms
- Automatic stack ejection
- Job separation
- Reliable inserter feeding

High Stack, High Speed

Maximize productivity in your fanfold print-to-mail operation with the RS Fanfold HS solution. This space-efficient system produces top quality fanfold stacks from pinless or pinfed roll paper for bulk feeding of inserters or other finishing equipment. Plus, the RS Fanfold HS positions you well for the future. The RSF5 Folder's ability to run up to 700 feet per minute ensures compatibility with the newest, fastest printers for years to come.

Top speed is not the only top performance feature of the RS Fanfold HS. The Folder includes a unique perforation compression technology, to create a flat stack for the most reliable inserter feeding. RS Fanfold HS minimizes labor requirements as well. The system builds 39" (990 mm) high

fanfold stacks for long print and inserter runs, automatically ejecting the stack onto a fanfold trolley. Two stacks may be formed before unloading is required. The RSF5 Folder's automatic thread-up and automatic form-size change features and color touch-screen control panel also make it easier on your operators. And, all of this is accomplished in a very small footprint.

As with all of our products, the RS Fanfold HS is compatible with today's most advanced digital printers and can be adapted to meet your printing needs. Global service and around-the-clock support help ensure our reputation as the industry's reliability leader. Count on Lasermax Roll Systems to help you do more with digital print.

RS Fanfold HS

The RS Fanfold HS solution is comprised of the RS Unwind and RSF5 Folder.

The surface-driven RS Unwind features no-lift mounting and a self-centering shaftless design and begins by unwinding a web up to 21 inches wide into a digital printer. The RSF5 Folder automatically threads-up the pinless or pinfed paper web, and automatically adjusts for varying form lengths – no gear change is required.



Automatic stack eject.

The Folder builds a stack up to 39" high, continually compressing the perforation folds to

ensure a flat stack for reliable inserter feeding. When the maximum height is reached, the stack is automatically ejected onto a fanfold trolley and a new stack begins forming immediately, allowing the printer and folder to continue working nonstop.



Space saving transfer.

The full trolley is then moved to an inserter where forms may be fed directly from the fanfold trolley. Fanfold trolleys are stackable and compact, minimizing space requirements. A removable handle facilitates trolley movement. A retractable "seat belt" holds the fanfold stack firmly in place.

For internal report and sysout applications, markless job separation functionality is included in the RSF5 Folder. When a markless signal is not available, an optional mark separation sensor kit may be added.

All components use standard power, are mobile, modular, compact, and are designed to dramatically improve workflow.

Optional Capabilities



RST5 Stack Turner
Enable feeding of both A-Z and Z-A forms to inserters. Off-line operation.

StackRack loader

For operations with a significant investment in Lasermax Roll Systems' StackRack carts, a StackRack loader is available to enable use of these carts with the RS Fanfold HS system.

Inserter infeeds

Ensure smooth and reliable paper flow. Passive or powered models to match your inserter.

Web Vision™

Capture large, high-resolution images of the entire web with no operator adjustments. Web Vision reviews bar codes for readability, detects small image artifacts, and more.

Roll carts

Easily move, store and load paper rolls.

Duplex print registration sensor kit

Align duplex pre-printed web.

Specifications

Performance / Media

Speed max. 500 ft/min 2.50 m/sec
(speeds over 350 ft/min for gradual start/stop printers.)

Print Simplex, Duplex

Feeding Pinless, Pinfed

Paper weight 16–42# bond 60–158 gsm

Roll diameter 4"–50" 100 mm–1270 mm

Web width 8"–21" 203 mm–533 mm

Form length

1 per fold 8.33"–17" 212 mm–432 mm

2 per fold 4.166"–8.5" 106 mm–216 mm
(14"–17" form lengths may require testing.)

Stack height 2"–39" 51 mm–991 mm
about 500–10,000 sheets

Electrical

Power 110–120 VAC 50/60 Hz, 12A, or
220–240 VAC 50/60 Hz, 6A

Configuration Example

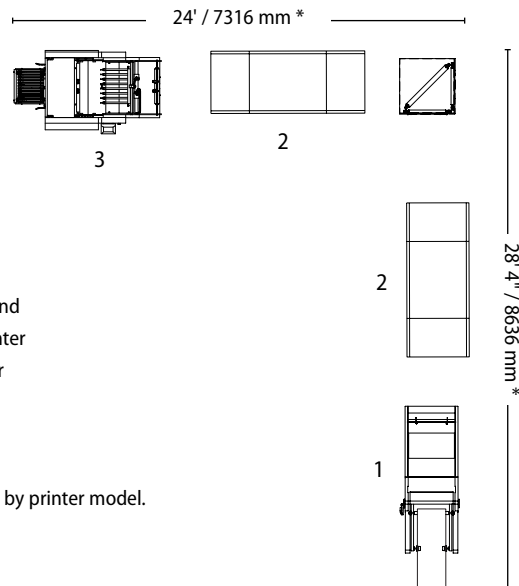

- 1 RSU5 Unwind
- 2 Duplex Printer
- 3 RSF5 Folder

*Length will vary by printer model.